

Bike Wash

The future of individual means of transportation is environmentally friendly.

The bicycle plays a central role, especially in our cities. Step by step, urban areas become more adapt for cyclists – fewer cars, more bikes. The environment as well as the people profit from less noise and pollution through a better quality of life. The bike sport in general is on an all time high. The increasingly high numbers of bikes and e-bikes naturally need to be kept clean and functional – an expansion of bike-infrastructure especially at highly frequented places seems to be the consequence.

We want to be part of this development and actively act towards it. We want to offer a service that cleans and maintains your bike efficiently and in an environmentally friendly way. Looking for ways to achieve these goals, we found CycleWASH. The market leader in the area of bicycle wash facilities offers exactly

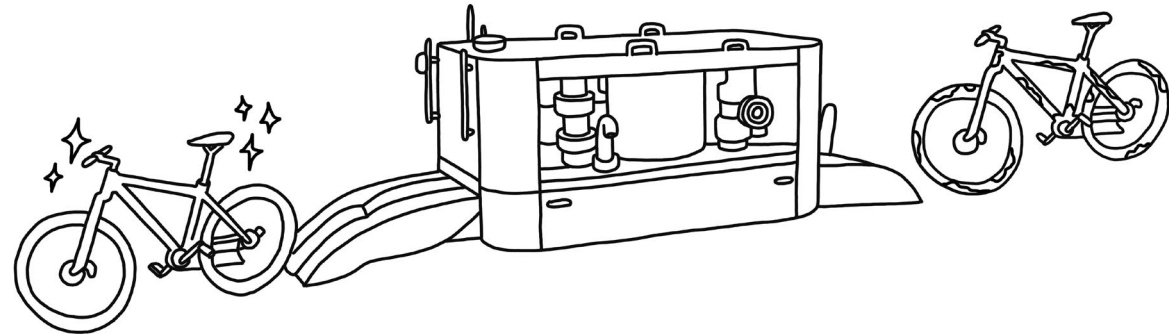

what we were looking for to contribute to a sustainable mode of transportation and also has a really cool name.

Our new CycleWASH Pro Silver-Black even has an Eco mode, which does not need a fixed water connection, but can be filled and refilled by hand. Thanks to the integrated water cycle and -filter the water is constantly circulated and cleaned. Thus, the usage only comes up to three litres of cold water per wash cycle and the bike is being cleaned without adding any detergents, keeping the energy usage and thus the CO2 emissions on a very low level.



Lukas, Project Manager Business Development,

is looking forward to testing out the new bike wash facility next to the Salewa Bivac come spring and invites you to drop by for a coffee and a bike wash.